

Please check the examination details below before entering your candidate information

Candidate surname

Other names

**Pearson Edexcel**  
**International**  
**Advanced Level**

Centre Number

--	--	--	--	--

Candidate Number

--	--	--	--	--

**Friday 1 November 2019**

Morning (Time: 1 hour 35 minutes)

Paper Reference **WPH05/01**

**Physics**

**Advanced**

**Unit 5: Physics from Creation to Collapse**

**You must have:**

Ruler

Total Marks

## Instructions

- Use **black** ink or ball-point pen.
- **Fill in the boxes** at the top of this page with your name, centre number and candidate number.
- Answer **all** questions.
- Answer the questions in the spaces provided  
– *there may be more space than you need.*

## Information

- The total mark for this paper is 80.
- The marks for **each** question are shown in brackets  
– *use this as a guide as to how much time to spend on each question.*
- Questions labelled with an **asterisk** (\*) are ones where the quality of your written communication will be assessed  
– *you should take particular care with your spelling, punctuation and grammar, as well as the clarity of expression, on these questions.*
- The list of data, formulae and relationships is printed at the end of this booklet.
- Candidates may use a scientific calculator.

## Advice

- Read each question carefully before you start to answer it.
- Try to answer every question.
- Check your answers if you have time at the end.

Turn over ►

P58396A

©2019 Pearson Education Ltd.

1/1/1/1/



  
**Pearson**

## SECTION A

Answer ALL questions.

For questions 1–10, in Section A, select one answer from A to D and put a cross in the box . If you change your mind, put a line through the box  and then mark your new answer with a cross .

- 1 Recent measurements indicate that the value of the Hubble constant is greater than previously estimated.

Which of the following statements could be a consequence of this?

- A The universe might be bigger than we thought.
- B The universe might not be as big as we thought.
- C The universe might be older than we thought.
- D The universe might not be as old as we thought.

(Total for Question 1 = 1 mark)

- 2 It is claimed on a website that the conditions in the core of a star are perfect for fusion.

Which of the following statements about the interior of a star best supports this claim?

- A The density is very high and the temperature is moderate.
- B The density is moderate and the temperature is very high.
- C The density and temperature are both very high.
- D The density and temperature are both moderate.

(Total for Question 2 = 1 mark)

DO NOT WRITE IN THIS AREA

DO NOT WRITE IN THIS AREA

DO NOT WRITE IN THIS AREA



- 3 A star is moving towards the Earth with a velocity of  $1.2 \times 10^6 \text{ m s}^{-1}$ . Light of wavelength 780 nm is emitted from the star.

What would be the wavelength of the light, in nm, recorded by an observer on the Earth?

- A  $780 + \left(\frac{1.2}{300}\right) \times 780$
- B  $780 + \left(\frac{300}{1.2}\right) \times 780$
- C  $780 - \left(\frac{1.2}{300}\right) \times 780$
- D  $780 - \left(\frac{300}{1.2}\right) \times 780$

(Total for Question 3 = 1 mark)

- 4 A student used a Geiger-Müller tube and counter to measure the count near to a radioactive source for one minute. He used this value to calculate the count rate due to the source in Bq.

Which of the following would decrease the percentage uncertainty in the student's value for the activity?

- A Add the background count to the measured count.
- B Increase the counting time to 10 minutes.
- C Increase the distance of the Geiger-Müller tube from the source.
- D Subtract the background count from the calculated count rate.

(Total for Question 4 = 1 mark)



- 5 A mass was hung from the end of spring 1 and set into vertical oscillation. Another mass was hung from the end of spring 2 and also set into vertical oscillation.

The maximum velocity, angular frequency and amplitude of the mass on each spring are summarised in the table below.

	spring 1	spring 2
Maximum velocity	$v_1$	$v_2$
Angular frequency	$\omega$	$2\omega$
Amplitude	$A$	$A/2$

Which of the following statements about the maximum velocities is correct?

- A  $v_1 = \frac{v_2}{4}$
- B  $v_1 = \frac{v_2}{2}$
- C  $v_1 = v_2$
- D  $v_1 = 2v_2$

(Total for Question 5 = 1 mark)

- 6 A pendulum is driven into oscillation and resonance occurs.

What happens to the maximum damping force as the amplitude of oscillation increases?

- A The maximum damping force gradually decreases.
- B The maximum damping force gradually increases.
- C The maximum damping force increases and then decreases.
- D The maximum damping force stays constant.

(Total for Question 6 = 1 mark)

- 7 The temperature of a fixed volume of an ideal gas is increased from 300 K to 330 K.

Which of the following statements is **not** true?

- A The internal energy of the gas increases by 10%.
- B The kinetic energy of the molecules in the gas increases by 10%.
- C The potential energy of the molecules in the gas increases by 10%.
- D The value of  $\langle c^2 \rangle$  for the molecules in the gas increases by 10%.

(Total for Question 7 = 1 mark)



- 8 A fixed mass of an ideal gas exerts a pressure  $p$ . The volume occupied by the gas is doubled, and the absolute temperature of the gas is halved.

What is the new pressure exerted by the gas?

- A  $0.25p$   
 B  $0.5p$   
 C  $2p$   
 D  $4p$

(Total for Question 8 = 1 mark)

- 9 Star X has a luminosity  $L$  and is a distance  $x$  from the Earth. The radiation flux received from this star is  $F$ .

Star Y has a luminosity  $3L$  and is a distance  $2x$  from the Earth.

What is the radiation flux received from star Y?

- A  $3F/4$   
 B  $2F/3$   
 C  $4F/3$   
 D  $3F/2$

(Total for Question 9 = 1 mark)



10 The graph below shows how the velocity  $v$  varies with time  $t$  for a particle undergoing simple harmonic motion.

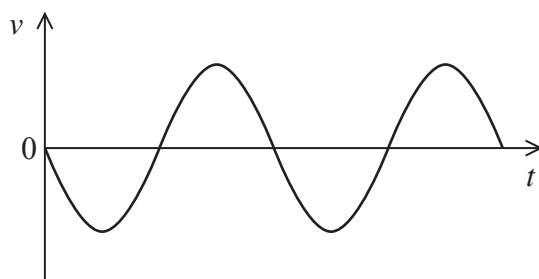

Select the graph that shows how the acceleration  $a$  varies with  $t$  over the same time interval.

A

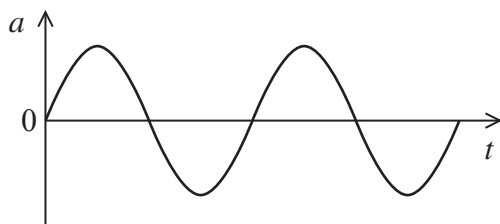

B

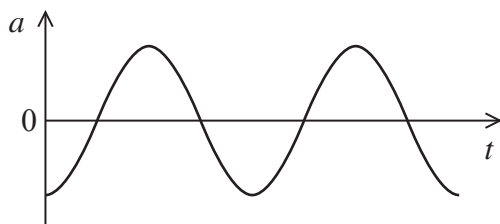

C

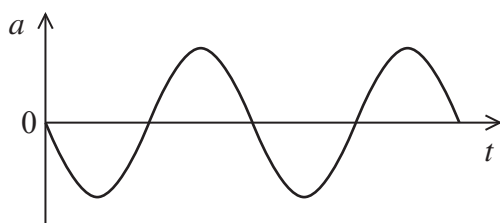

D

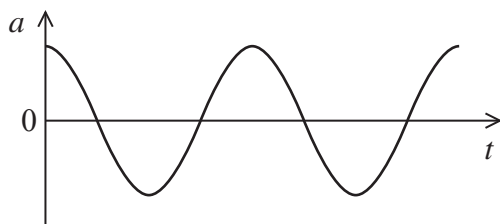

(Total for Question 10 = 1 mark)

TOTAL FOR SECTION A = 10 MARKS

DO NOT WRITE IN THIS AREA

DO NOT WRITE IN THIS AREA

DO NOT WRITE IN THIS AREA



SECTION B

Answer ALL questions in the spaces provided.

- 11 The graph shows how the recessional velocity of some galaxies depends on their distance from the Earth.

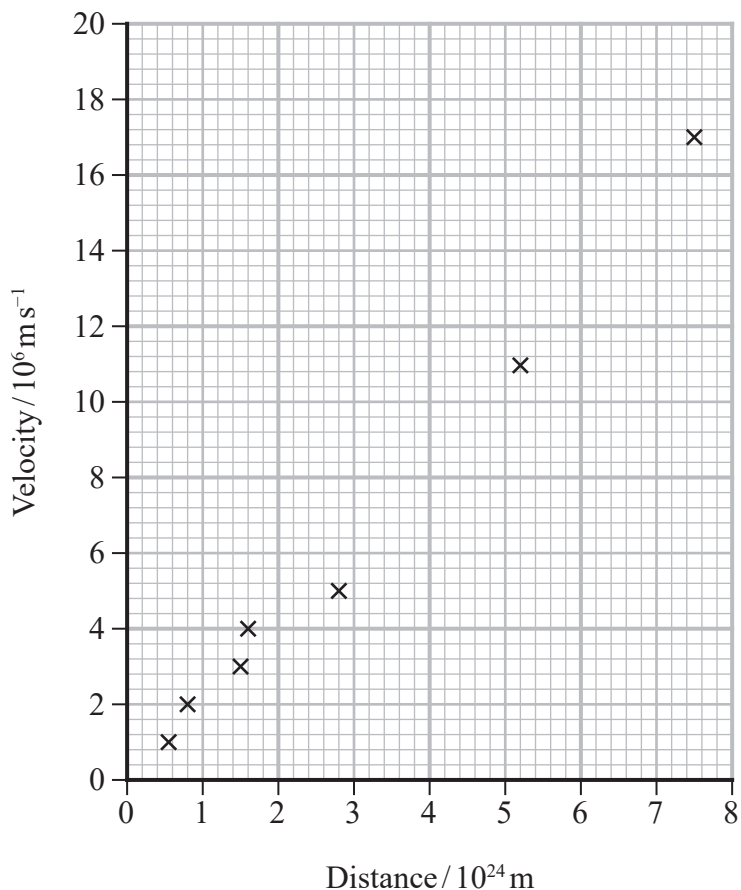

Determine an age for the universe in seconds.

(4)

.....

.....

.....

.....

.....

.....

.....

Age of the universe = ..... s

(Total for Question 11 = 4 marks)



12 A coffee is made with hot water and milk.

(a) The water used to make the coffee is heated to its boiling point.

Describe the changes in the internal energy of the water while it is boiling.

(2)

.....

.....

.....

(b) A cup contains 45 g of coffee at a temperature of 73.5 °C. Milk at a temperature of 62.0 °C is added to the coffee.

The temperature of the mixture immediately after adding the milk is 65.5 °C.

Calculate the mass of milk that was added to the coffee.

specific heat capacity of coffee = 4200 J kg<sup>-1</sup> K<sup>-1</sup>

specific heat capacity of milk = 3900 J kg<sup>-1</sup> K<sup>-1</sup>

(3)

.....

.....

.....

.....

.....

Mass of milk = .....

**(Total for Question 12 = 5 marks)**



- 13 The image below of a healthy man was taken with an infrared camera. Darker areas on the image represent areas of higher temperature.



From the image it was estimated that the average skin temperature of the man was 307 K.

- (a) Calculate the peak emission wavelength  $\lambda_{\text{max}}$  of the thermal radiation emitted by the man.

Treat the man as a black body radiator.

(2)

$$\lambda_{\text{max}} = \dots\dots\dots$$



DO NOT WRITE IN THIS AREA

DO NOT WRITE IN THIS AREA

DO NOT WRITE IN THIS AREA

(b) Calculate the rate  $P$  at which thermal energy is radiated from the man. Treat the man as a black body radiator.

surface area of man =  $1.20 \text{ m}^2$

(2)

.....

.....

.....

.....

$P =$  .....

(c) In practice, the net rate of energy loss by thermal radiation is different from that given by the calculation in part (b). One reason is that the man is not a perfect black body radiator. Suggest two other reasons.

(2)

.....

.....

.....

.....

**(Total for Question 13 = 6 marks)**



DO NOT WRITE IN THIS AREA

DO NOT WRITE IN THIS AREA

DO NOT WRITE IN THIS AREA

14 Mercury is the smallest planet in the Solar System and the closest planet to the Sun. Its orbital period around the Sun is the shortest of all the planets in the Solar System.

- (a) Mercury takes  $7.60 \times 10^6$  s to make one complete orbit about the Sun. Calculate the radius of this orbit. You may assume that the orbit is circular.

mass of Sun =  $1.99 \times 10^{30}$  kg

(3)

.....

.....

.....

.....

.....

.....

.....

.....

.....

.....

Radius of orbit = .....



DO NOT WRITE IN THIS AREA

DO NOT WRITE IN THIS AREA

DO NOT WRITE IN THIS AREA

(b) (i) Derive an expression for the gravitational field strength  $g$  at a distance  $R$  from a point mass  $M$ .

(2)

.....

.....

.....

.....

.....

(ii) Calculate  $g$  at the surface of a uniform sphere with the same mass and radius as Mercury.

mass of Mercury =  $3.30 \times 10^{23}$  kg

radius of Mercury =  $2.44 \times 10^6$  m

(2)

.....

.....

.....

.....

$g =$  .....

**(Total for Question 14 = 7 marks)**



15\*(a) Observation of the night sky, over time, shows changes in the positions of some of the stars. The diagram below represents a group of stars in a particular field of view over a period of one year.



January 2018



July 2018



January 2019

Explain the differences in the field of view over the period January 2018 to January 2019. (4)

.....

.....

.....

.....

.....

.....

.....

.....

.....

.....

.....

.....

.....

.....

.....

.....

.....

.....

.....

.....

.....

.....

DO NOT WRITE IN THIS AREA

DO NOT WRITE IN THIS AREA

DO NOT WRITE IN THIS AREA

(b) To measure the distances to nearby galaxies, astronomers use stars known as standard candles within those galaxies.

Describe how standard candles can be used to determine distances to galaxies.

(3)

.....

.....

.....

.....

.....

.....

.....

.....

.....

**(Total for Question 15 = 7 marks)**



16 The photograph shows a musical box mechanism.

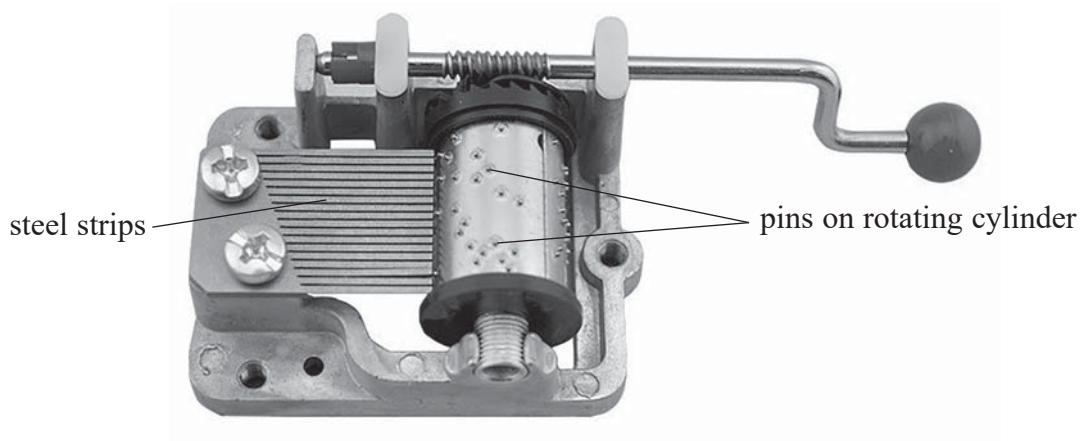

As the cylinder rotates, sound is created when pins on the cylinder strike the steel strips. One end of each strip is fixed and the other end is set into oscillation. Each strip oscillates with simple harmonic motion at a different frequency.

(a) State the condition for an oscillation to be simple harmonic.

(2)

.....

.....

.....

.....

(b) The end of one steel strip moves through 3.0 mm from one extreme position to the other extreme position, and makes 1600 complete oscillations in 5.0 s.

Calculate the maximum acceleration of this end of the steel strip.

(3)

.....

.....

.....

.....

.....

.....

Maximum acceleration = .....



DO NOT WRITE IN THIS AREA

DO NOT WRITE IN THIS AREA

DO NOT WRITE IN THIS AREA

(c) The sound made by the musical box mechanism is quiet, but it is observed that when the mechanism is placed on a wooden table there is a large increase in the loudness of the sound.

Explain this observation.

(3)

.....

.....

.....

.....

.....

.....

.....

.....

.....

.....

**(Total for Question 16 = 8 marks)**





(b) Betelgeuse and Rigel A are two of the brightest stars in the night sky. Although both stars have about the same luminosity, Rigel A has a much higher surface temperature than Betelgeuse.

Explain how this information can be used to determine the relative sizes of the two stars. (3)

.....

.....

.....

.....

.....

.....

.....

**(Total for Question 17 = 8 marks)**



- 18 Tyres for racing bicycles are often filled with nitrogen gas rather than air. The tyres are inflated using small cylinders filled with nitrogen gas at high pressure. The photograph shows such a cylinder.



- (a) The cylinder has a volume of  $7.25 \times 10^{-5} \text{ m}^3$  and contains  $6.85 \times 10^{22}$  molecules of nitrogen gas. The temperature of the nitrogen gas is  $22.0^\circ\text{C}$ .

- (i) Show that the pressure exerted by the nitrogen gas in the cylinder is about  $3.9 \times 10^6 \text{ Pa}$ .

(3)

- (ii) Nitrogen gas at a temperature of  $22.0^\circ\text{C}$  is used to fill a bicycle tyre of volume  $1.17 \times 10^{-3} \text{ m}^3$ .

Show that 3 gas cylinders contain the amount of nitrogen gas needed to fill the tyre to a pressure of  $6.55 \times 10^5 \text{ Pa}$ .

(2)



(iii) In practice, more than 3 cylinders of nitrogen gas may be needed to fill the tyre to a pressure of  $6.55 \times 10^5$  Pa.

Suggest a reason why.

(1)

.....

.....

(b) When the bicycle is in use, the pressure in the tyre falls more slowly if nitrogen gas is used to fill the tyres instead of air.

Air is a mixture of mostly nitrogen and oxygen. Nitrogen molecules are larger than oxygen molecules.

Suggest why the pressure in the tyre falls more slowly with nitrogen gas.

(2)

.....

.....

.....

.....

**(Total for Question 18 = 8 marks)**

DO NOT WRITE IN THIS AREA

DO NOT WRITE IN THIS AREA

DO NOT WRITE IN THIS AREA



DO NOT WRITE IN THIS AREA

DO NOT WRITE IN THIS AREA

DO NOT WRITE IN THIS AREA

19 When a stable phosphorus (P) nucleus is bombarded with deuterium (H-2) nuclei a radioactive isotope of phosphorus (P-32) is formed.

- (a) (i) Complete the nuclear reaction representing the absorption of deuterium by phosphorus.

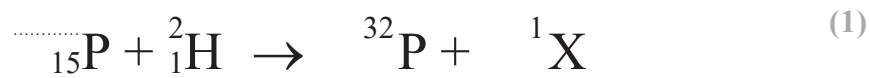

- (ii) Identify particle X.

(1)

X = .....

- (iii) Calculate the energy  $\Delta E$  released in J when the stable phosphorus absorbs a deuterium nucleus.

	Mass/u
Proton	1.007276
Neutron	1.008665
Deuterium	2.014102
P-30	29.978314
P-31	30.973762
P-32	31.973907

(4)

$\Delta E = \dots\dots\dots$  J



(b) P-32 is a beta emitter.

Beta radiation is absorbed as it passes through materials. The 'absorber density thickness' is the product of the density of the absorber material and its thickness.

The graph shows how the count rate from a beta source varies with the absorber density thickness.

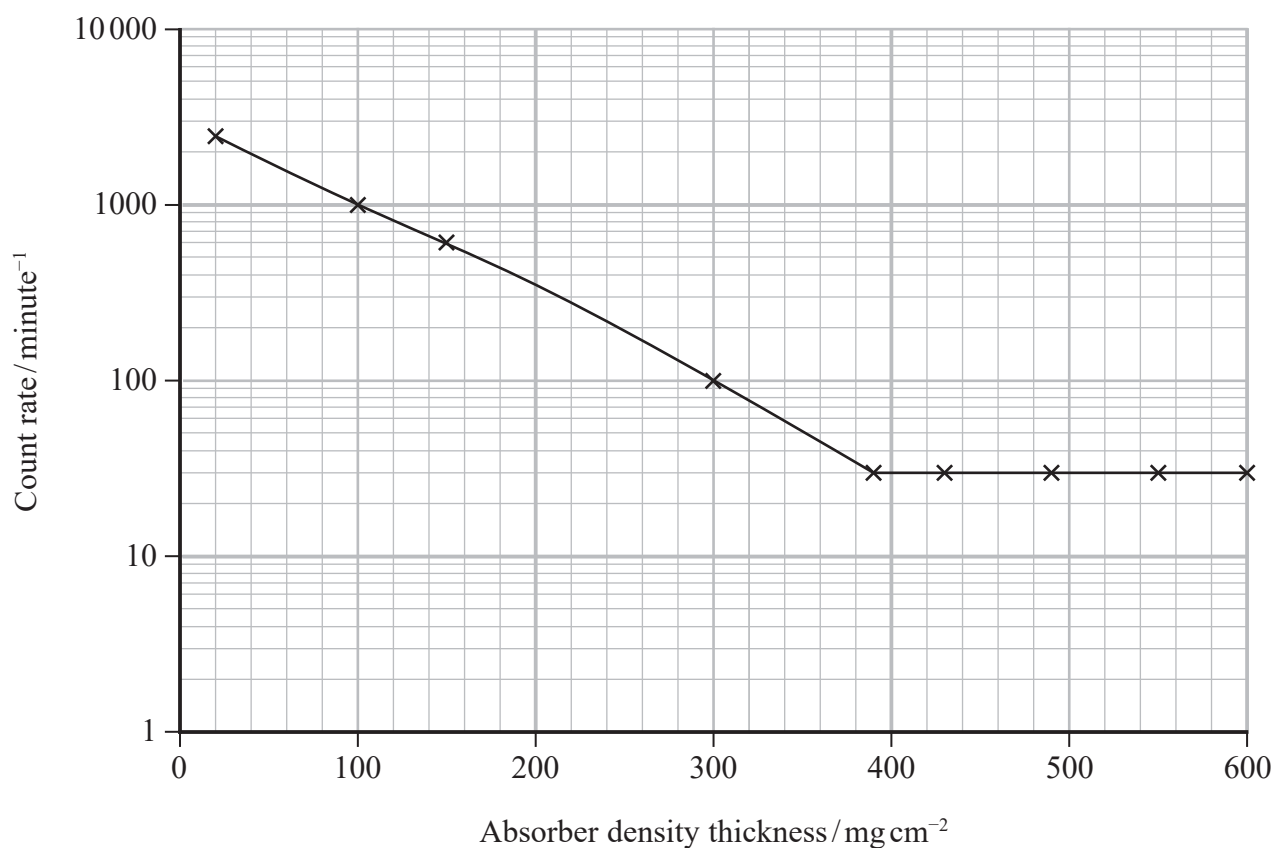

(i) Determine the minimum thickness of aluminium that would completely absorb the beta radiation.

$$\text{density of aluminium} = 2700 \text{ mg cm}^{-3}$$

(3)

Minimum thickness of aluminium = .....



(ii) Suggest why there is still a count rate even when all the beta radiation from the source has been absorbed.

(1)

(iii) Explain one precaution, other than shielding, that must be taken when using a source that emits beta particles.

(2)

(c) At a particular instant, a sample of P-32 contains  $1.32 \times 10^{11}$  atoms.

(i) Calculate the activity of the sample at this instant.

half-life of P-32 = 14.3 days

1 day = 86400 s

(3)

Activity of sample = .....

DO NOT WRITE IN THIS AREA

DO NOT WRITE IN THIS AREA

DO NOT WRITE IN THIS AREA



P 5 8 3 9 6 A 0 2 3 2 8

(ii) Calculate the activity of the sample of P-32 one day later.

(2)

.....

.....

.....

.....

.....

Activity one day later = .....

**(Total for Question 19 = 17 marks)**

---

**TOTAL FOR SECTION B = 70 MARKS**

**TOTAL FOR PAPER = 80 MARKS**

DO NOT WRITE IN THIS AREA

DO NOT WRITE IN THIS AREA

DO NOT WRITE IN THIS AREA



### List of data, formulae and relationships

Acceleration of free fall	$g = 9.81 \text{ m s}^{-2}$	(close to Earth's surface)
Boltzmann constant	$k = 1.38 \times 10^{-23} \text{ J K}^{-1}$	
Coulomb's law constant	$k = 1/4\pi\epsilon_0$ $= 8.99 \times 10^9 \text{ N m}^2 \text{ C}^{-2}$	
Electron charge	$e = -1.60 \times 10^{-19} \text{ C}$	
Electron mass	$m_e = 9.11 \times 10^{-31} \text{ kg}$	
Electronvolt	$1 \text{ eV} = 1.60 \times 10^{-19} \text{ J}$	
Gravitational constant	$G = 6.67 \times 10^{-11} \text{ N m}^2 \text{ kg}^{-2}$	
Gravitational field strength	$g = 9.81 \text{ N kg}^{-1}$	(close to Earth's surface)
Permittivity of free space	$\epsilon_0 = 8.85 \times 10^{-12} \text{ F m}^{-1}$	
Planck constant	$h = 6.63 \times 10^{-34} \text{ J s}$	
Proton mass	$m_p = 1.67 \times 10^{-27} \text{ kg}$	
Speed of light in a vacuum	$c = 3.00 \times 10^8 \text{ m s}^{-1}$	
Stefan-Boltzmann constant	$\sigma = 5.67 \times 10^{-8} \text{ W m}^{-2} \text{ K}^{-4}$	
Unified atomic mass unit	$u = 1.66 \times 10^{-27} \text{ kg}$	

#### Unit 1

##### Mechanics

Kinematic equations of motion	$v = u + at$ $s = ut + \frac{1}{2}at^2$ $v^2 = u^2 + 2as$
Forces	$\Sigma F = ma$ $g = F/m$ $W = mg$
Work and energy	$\Delta W = F\Delta s$ $E_k = \frac{1}{2}mv^2$ $\Delta E_{\text{grav}} = mg\Delta h$

##### Materials

Stokes' law	$F = 6\pi\eta rv$
Hooke's law	$F = k\Delta x$
Density	$\rho = m/V$
Pressure	$p = F/A$
Young modulus	$E = \sigma/\epsilon$ where Stress $\sigma = F/A$ Strain $\epsilon = \Delta x/x$
Elastic strain energy	$E_{\text{el}} = \frac{1}{2}F\Delta x$



## Unit 2

### Waves

Wave speed  $v = f\lambda$

Refractive index  ${}_1\mu_2 = \sin i / \sin r = v_1 / v_2$

### Electricity

Potential difference  $V = W/Q$

Resistance  $R = V/I$

Electrical power, energy and efficiency  
 $P = VI$   
 $P = I^2R$   
 $P = V^2/R$   
 $W = VI t$

$$\% \text{ efficiency} = \frac{\text{useful energy output}}{\text{total energy input}} \times 100$$

$$\% \text{ efficiency} = \frac{\text{useful power output}}{\text{total power input}} \times 100$$

Resistivity  $R = \rho l/A$

Current  
 $I = \Delta Q / \Delta t$   
 $I = nqvA$

Resistors in series  $R = R_1 + R_2 + R_3$

Resistors in parallel  
 $\frac{1}{R} = \frac{1}{R_1} + \frac{1}{R_2} + \frac{1}{R_3}$

### Quantum physics

Photon model  $E = hf$

Einstein's photoelectric equation  
 $hf = \phi + \frac{1}{2}mv_{\text{max}}^2$

DO NOT WRITE IN THIS AREA

DO NOT WRITE IN THIS AREA

DO NOT WRITE IN THIS AREA



## Unit 4

### Mechanics

Momentum	$p = mv$
Kinetic energy of a non-relativistic particle	$E_k = p^2/2m$
Motion in a circle	$v = \omega r$ $T = 2\pi/\omega$ $F = ma = mv^2/r$ $a = v^2/r$ $a = r\omega^2$

### Fields

Coulomb's law	$F = kQ_1Q_2/r^2$ where $k = 1/4\pi\epsilon_0$
Electric field	$E = F/Q$ $E = kQ/r^2$ $E = V/d$
Capacitance	$C = Q/V$
Energy stored in capacitor	$W = \frac{1}{2}QV$
Capacitor discharge	$Q = Q_0 e^{-t/RC}$
In a magnetic field	$F = BIl \sin \theta$ $F = Bqv \sin \theta$ $r = p/BQ$
Faraday's and Lenz's laws	$\epsilon = -d(N\phi)/dt$

### Particle physics

Mass-energy	$\Delta E = c^2 \Delta m$
de Broglie wavelength	$\lambda = h/p$

DO NOT WRITE IN THIS AREA

DO NOT WRITE IN THIS AREA

DO NOT WRITE IN THIS AREA



**Unit 5***Energy and matter*

Heating  $\Delta E = mc\Delta\theta$

Molecular kinetic theory  $\frac{1}{2}m\langle c^2 \rangle = \frac{3}{2}kT$

Ideal gas equation  $pV = NkT$

*Nuclear Physics*

Radioactive decay  $dN/dt = -\lambda N$

$$\lambda = \ln 2/t_{1/2}$$

$$N = N_0 e^{-\lambda t}$$

*Mechanics*

Simple harmonic motion

$$a = -\omega^2 x$$

$$a = -A\omega^2 \cos \omega t$$

$$v = -A\omega \sin \omega t$$

$$x = A \cos \omega t$$

$$T = 1/f = 2\pi/\omega$$

Gravitational force  $F = Gm_1 m_2 / r^2$

*Observing the universe*

Radiant energy flux  $F = L/4\pi d^2$

Stefan-Boltzmann law

$$L = \sigma T^4 A$$

$$L = 4\pi r^2 \sigma T^4$$

Wien's law  $\lambda_{\max} T = 2.898 \times 10^{-3} \text{ m K}$

Redshift of electromagnetic radiation  $z = \Delta\lambda/\lambda \approx \Delta f/f \approx v/c$

Cosmological expansion  $v = H_0 d$

