

Surname	Centre Number	Candidate Number
First name(s)		2



GCE AS/A LEVEL

2420U20-1



WEDNESDAY, 22 MAY 2024 – AFTERNOON

PHYSICS – AS unit 2 Electricity and Light

1 hour 30 minutes

For Examiner's use only		
Question	Maximum Mark	Mark Awarded
1.	6	
2.	7	
3.	14	
4.	9	
5.	9	
6.	6	
7.	10	
8.	8	
9.	11	
Total	80	

2420U201
01

ADDITIONAL MATERIALS

In addition to this paper you will require a calculator and a **Data Booklet**.

INSTRUCTIONS TO CANDIDATES

Use black ink or black ball-point pen. Do not use gel pen or correction fluid.

You may use a pencil for graphs and diagrams only.

Write your name, centre number and candidate number in the spaces at the top of this page.

Answer **all** questions.

Write your answers in the spaces provided in this booklet. If you run out of space, use the additional page(s) at the back of the booklet, taking care to number the question(s) correctly.

INFORMATION FOR CANDIDATES

The total number of marks available for this paper is 80.

The number of marks is given in brackets at the end of each question or part-question.

The assessment of the quality of extended response (QER) will take place in question 6.



JUN242420U20101

BLANK PAGE

**PLEASE DO NOT WRITE
ON THIS PAGE**



Answer **all** questions.

1. (a) Delyth has been given the task of constructing a resistor of resistance $56\ \Omega$ using wire labelled: **diameter** $0.15\ \text{mm}$, resistivity $4.9 \times 10^{-7}\ \Omega\ \text{m}$. Calculate the length of wire that she should use. [3]

.....

.....

.....

.....

.....

.....

- (b) Delyth tests this length of wire by placing it in the circuit shown.

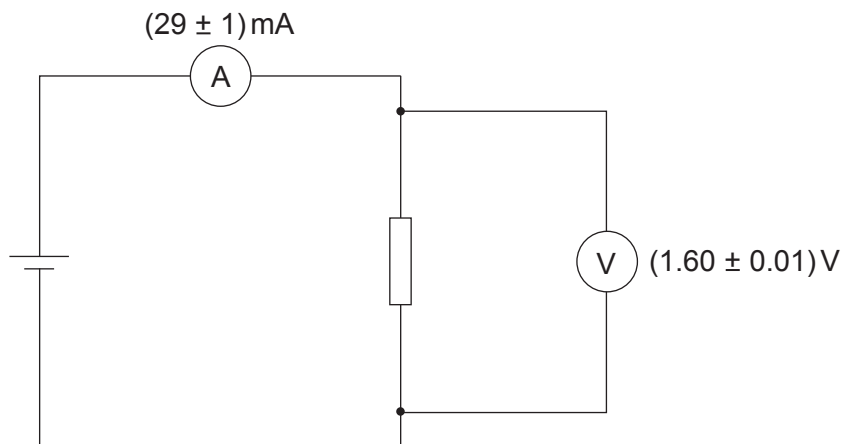

Delyth concludes from the meter readings, shown on the diagram, that her resistor does **not** have a resistance of $56\ \Omega$. Evaluate whether or not this is a valid conclusion. [3]

.....

.....

.....

.....

.....

.....



2.

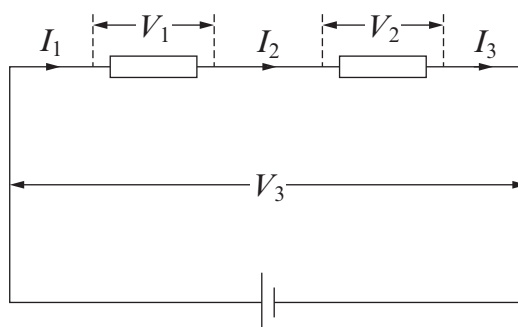

(a) For the series circuit shown, write equations that give the relationships between:

(i) the currents (only);

[1]

.....

(ii) the potential differences (only).

[1]

.....

(b) The diagram shows a circuit that can produce a range of output pds, V_{out} . The middle resistor is a uniform carbon conductor, XY, of resistance $20\ \Omega$. A sliding contact, S, can be moved up and down, making contact with the conductor at any point along it.

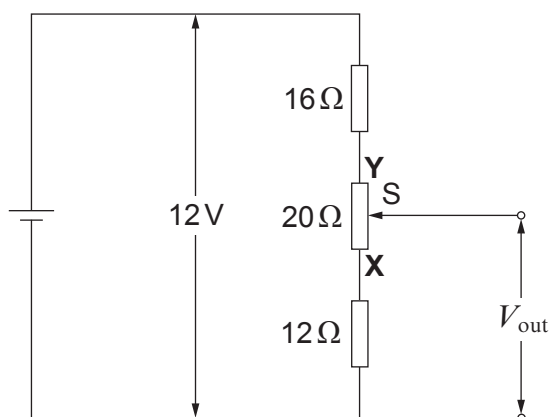

(i) Show clearly that when the sliding contact is at Y, $V_{\text{out}} = 8.0\text{V}$.

[2]

.....

.....

.....

(ii) Determine the value of V_{out} when the sliding contact is at X.

[1]

.....

.....



- (c) The circuit in (b) is to be modified to produce V_{out} ranging from 2V to 10V. The 12V battery and the 20Ω resistor with sliding contact are still to be used.

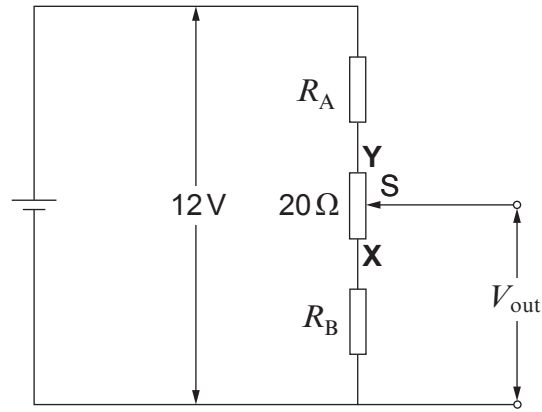

Design the new circuit, by giving the values for R_A and R_B .

[2]

.....

.....

.....

.....

2420U201
05

7



3. A battery has an emf of 12 V.

(a) (i) Explain what this statement means. [2]

.....

.....

(ii) State why it is usually a disadvantage for a battery to have an internal resistance. [1]

.....

.....

(b) The battery is included in the circuit shown.

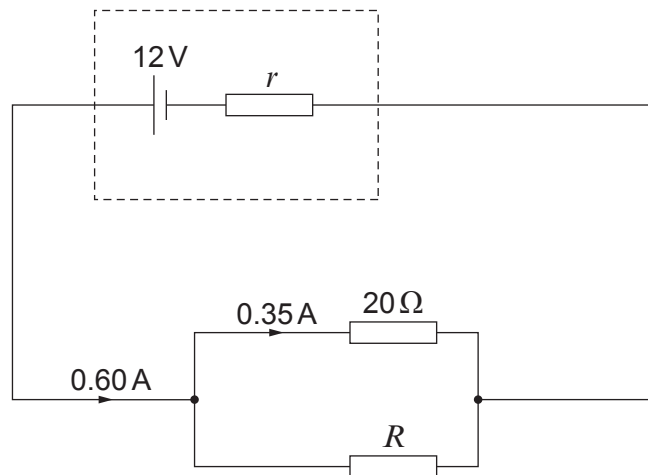

(i) Use the information shown on the circuit diagram to calculate:

I. the resistance, R . [2]

.....

.....

.....

II. the internal resistance, r . [2]

.....

.....

.....



(ii) I. Calculate the energy transferred in the $20\ \Omega$ resistor in 40 minutes. [2]

.....

.....

.....

II. State the energy transfer that occurs in the $20\ \Omega$ resistor and explain, in terms of the motion of free electrons, how it takes place. [2]

.....

.....

.....

(iii) Dafydd claims that if R is replaced by a higher resistance, but no other changes are made, the power dissipation **in the $20\ \Omega$ resistor** will increase. Evaluate this claim, showing clear reasoning. [3]

.....

.....

.....

.....

.....

.....

2420U201
07

14



4. (a) A progressive wave is travelling from left to right on a stretched string. A snapshot of the portion **XY** of the string at time $t = 0$ is shown.

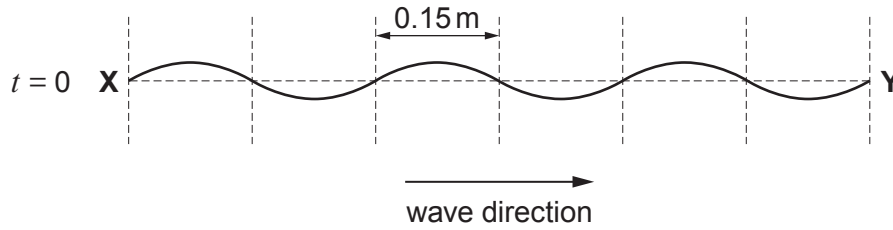

- (i) State the value of the wavelength. [1]

.....

- (ii) The periodic time is 100 ms. Calculate the **speed** of the waves. [2]

.....

.....

.....

- (iii) Carefully sketch, on the grids below, the wave along **XY** at times $t = 25$ ms and $t = 50$ ms. [2]

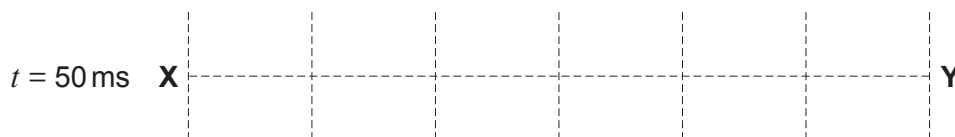
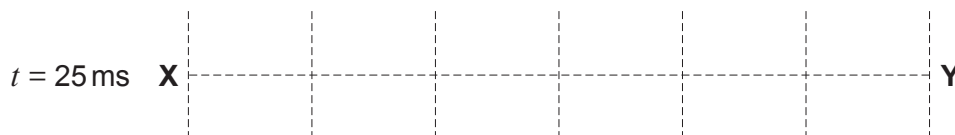

(b) If the string is attached to a fixed point to the right of **Y**, a stationary wave is observed on **XY**.

(i) Explain how this stationary wave arises. [2]

.....

.....

.....

.....

(ii) The diagram below shows **XY** at an instant ($t = 0$) when the stationary wave has maximum amplitude.

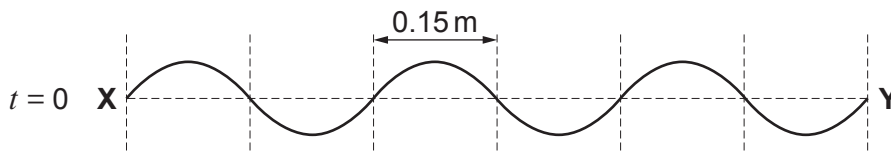

Carefully sketch, on the grids below, the wave along **XY** at times $t = 25$ ms and $t = 50$ ms. [2]

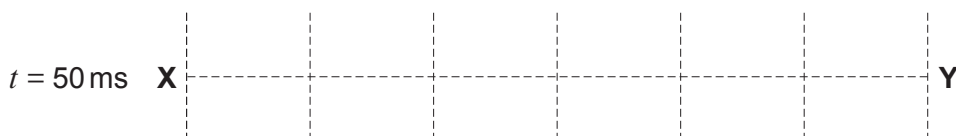
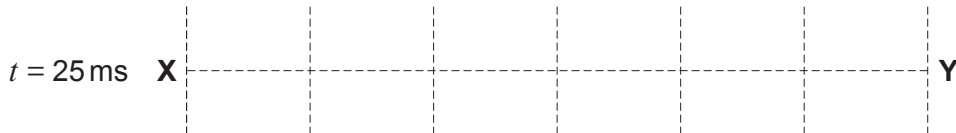

2420U201
09



5. (a) In the two-slit set-up shown, the centres of the bright fringes are 2.2 mm apart. S_1 and S_2 are slits with centres 0.45 mm apart, acting as in-phase sources.

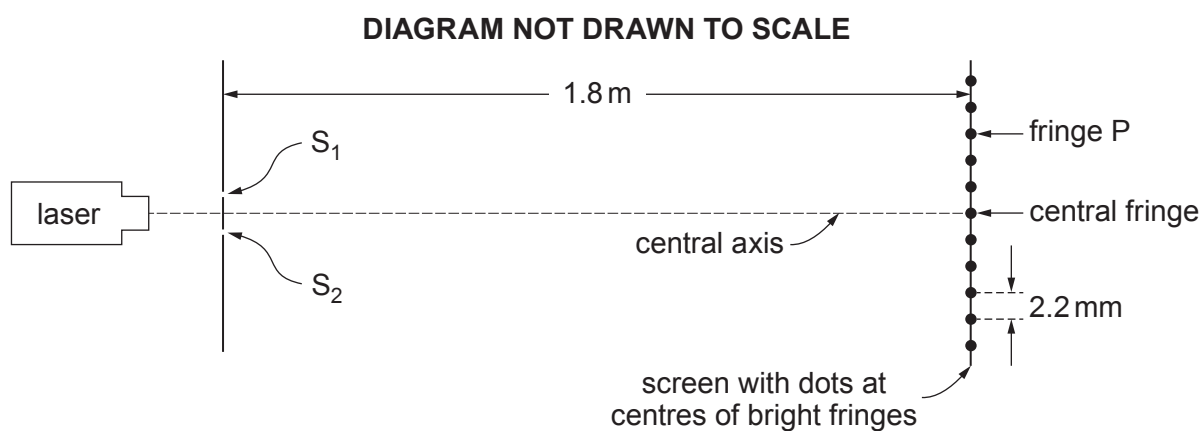

- (i) Explain the role of diffraction in producing the fringe pattern. [2]

.....

.....

.....

.....

- (ii) Calculate a value for the wavelength of the laser light. [2]

.....

.....

.....

.....

- (iii) Using your answer to (a)(ii) determine the path difference $S_2P - S_1P$ (see diagram), giving your reasoning. [3]

.....

.....

.....

.....

.....

.....

.....



- (b) Give **two** reasons why a diffraction grating would be expected to give a more precise value for the wavelength than the two-slit method. [2]

.....

.....

.....

9



BLANK PAGE

**PLEASE DO NOT WRITE
ON THIS PAGE**



7. Rhodri carries out an experiment to determine the refractive index, n , of a plastic in the form of a block of semi-circular cross-section.

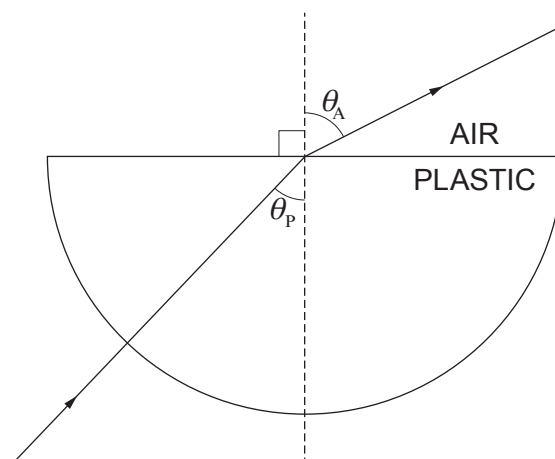

Rhodri places the block on paper and shines a narrow beam of light through the curved face, towards the circle centre. He measures angles θ_p and θ_A . He repeats the procedure for a range of angles of θ_p . His table of results is given, and his plot of $\sin \theta_A$ against $\sin \theta_p$.

$\theta_p / ^\circ$	$\sin \theta_p$	$\theta_A / ^\circ$	$\sin \theta_A$
0	0	0	0
5	0.087	8	0.139
10	0.174	16	0.276
15	0.259	25	0.423
20	0.342	34	0.559
25	0.423	42	0.669
30	0.500	54	0.809
35	66
40		—	

- (a) State why no bending of the beam occurs as it enters the curved face of the block. [1]

.....

.....

- (b) **Complete** the row of the table for $\theta_p = 35^\circ$ and **plot** the corresponding point on the grid opposite. [2]



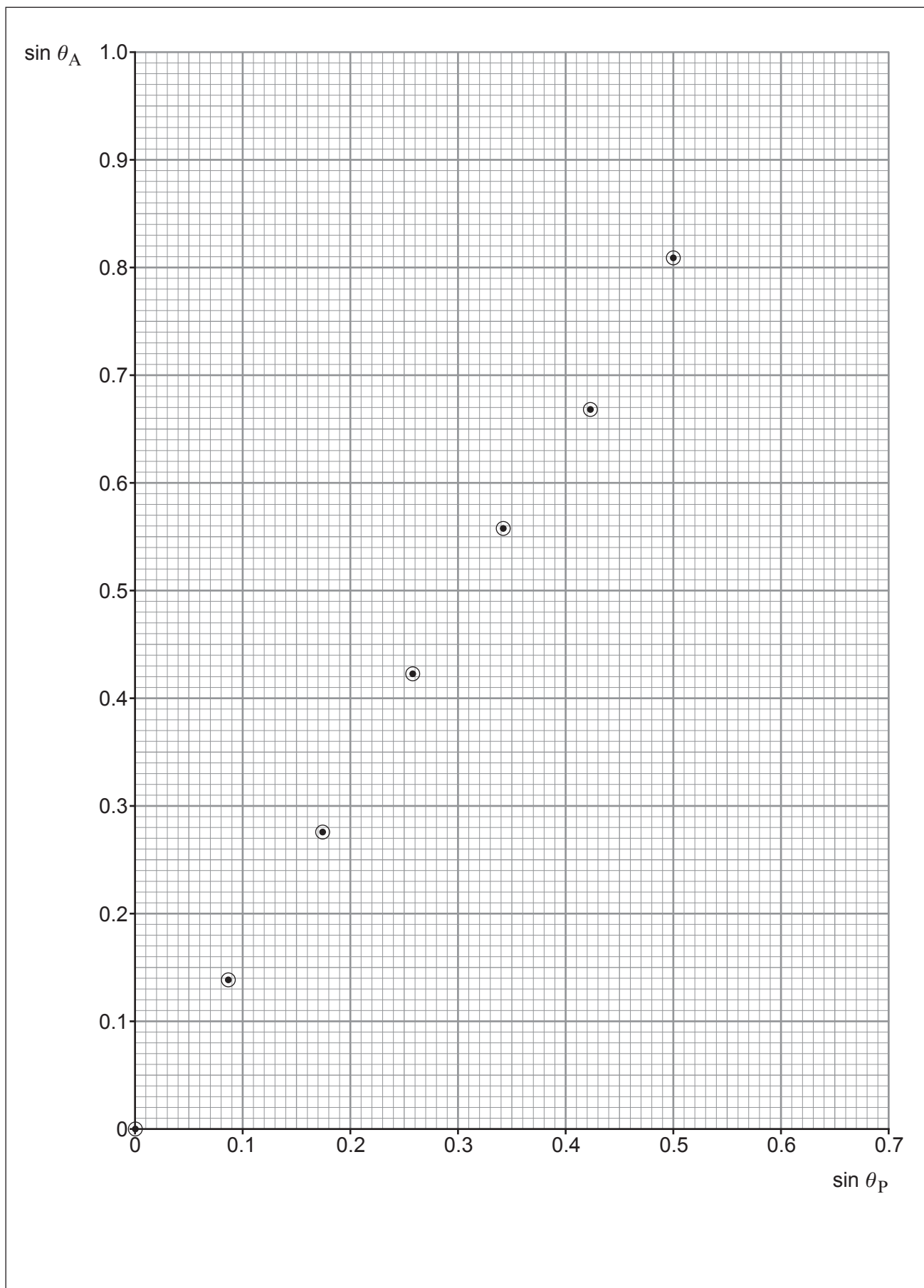

- (c) (i) Discuss whether the graph supports the law that $\sin \theta_A$ is proportional to $\sin \theta_P$. [3]

.....

.....

.....

.....

.....

- (ii) Determine a value for the refractive index, n . [2]

.....

.....

.....

.....

- (d) Rhodri could not obtain a value for θ_A when $\theta_P = 40^\circ$. Show why this had to be the case. [2]

.....

.....

.....

.....



BLANK PAGE

**PLEASE DO NOT WRITE
ON THIS PAGE**



8. (a) (i) State, **in terms of energy**, the meanings of the two right-hand terms in Einstein's photoelectric equation,

$$E_{k\max} = hf - \phi$$

I. hf [1]

II. ϕ [1]

- (ii) Ultraviolet radiation of frequency 7.90×10^{14} Hz is shone on to surfaces of barium and magnesium in turn, using the apparatus shown.

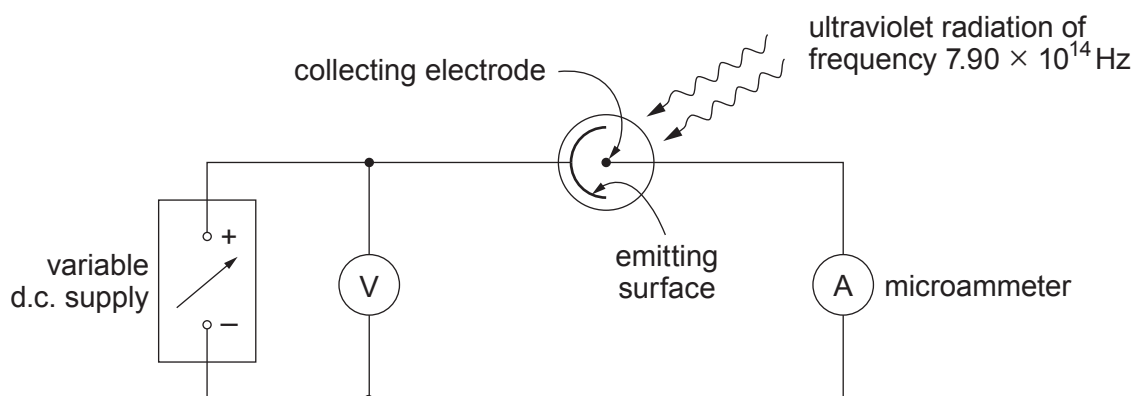

Determine whether or not electrons are emitted from each surface and, if so, the minimum pd needed to reduce the current shown by the microammeter to zero. [3]

[Work function of barium = 4.03×10^{-19} J;
Work function of magnesium = 5.86×10^{-19} J]

.....

.....

.....

.....

.....

.....

.....

.....



(b) Photovoltaic panels transfer some of the energy from the Sun into electrical energy. It has been estimated that a quarter of the UK's electrical energy needs could be provided by photovoltaic panels covering an area equal to the total area of roofs on UK buildings. Discuss whether it should be compulsory to have photovoltaic panels on all roofs. [3]

.....

.....

.....

.....

.....

.....

.....

.....

8



9. A simplified energy level diagram for a three-level laser is given below.

P ————— 2.25 eV

U ————— 1.79 eV

G ————— 0

(a) The laser emits light by means of stimulated emission involving levels U and G.

(i) Explain what is meant by stimulated emission involving levels U and G. [2]

.....

.....

.....

(ii) State why there must be more electrons in U than in G for light amplification to occur. [1]

.....

.....

(b) Calculate the wavelength of the light emitted by stimulated emission. [3]

.....

.....

.....

.....



(c) The laser emits light at a power of 0.60 W.

(i) Show that approximately 2×10^{18} photons are emitted per second. [1]

.....

.....

.....

(ii) Calculate the magnitude of the momentum of an emitted photon. [2]

.....

.....

.....

(iii) The light from the laser strikes a shiny surface at right angles. Assuming that the surface reflects all the light, calculate the force exerted on the surface by the light. [2]

.....

.....

.....

.....

END OF PAPER

11



BLANK PAGE

**PLEASE DO NOT WRITE
ON THIS PAGE**

